

A5s

Receiving Card

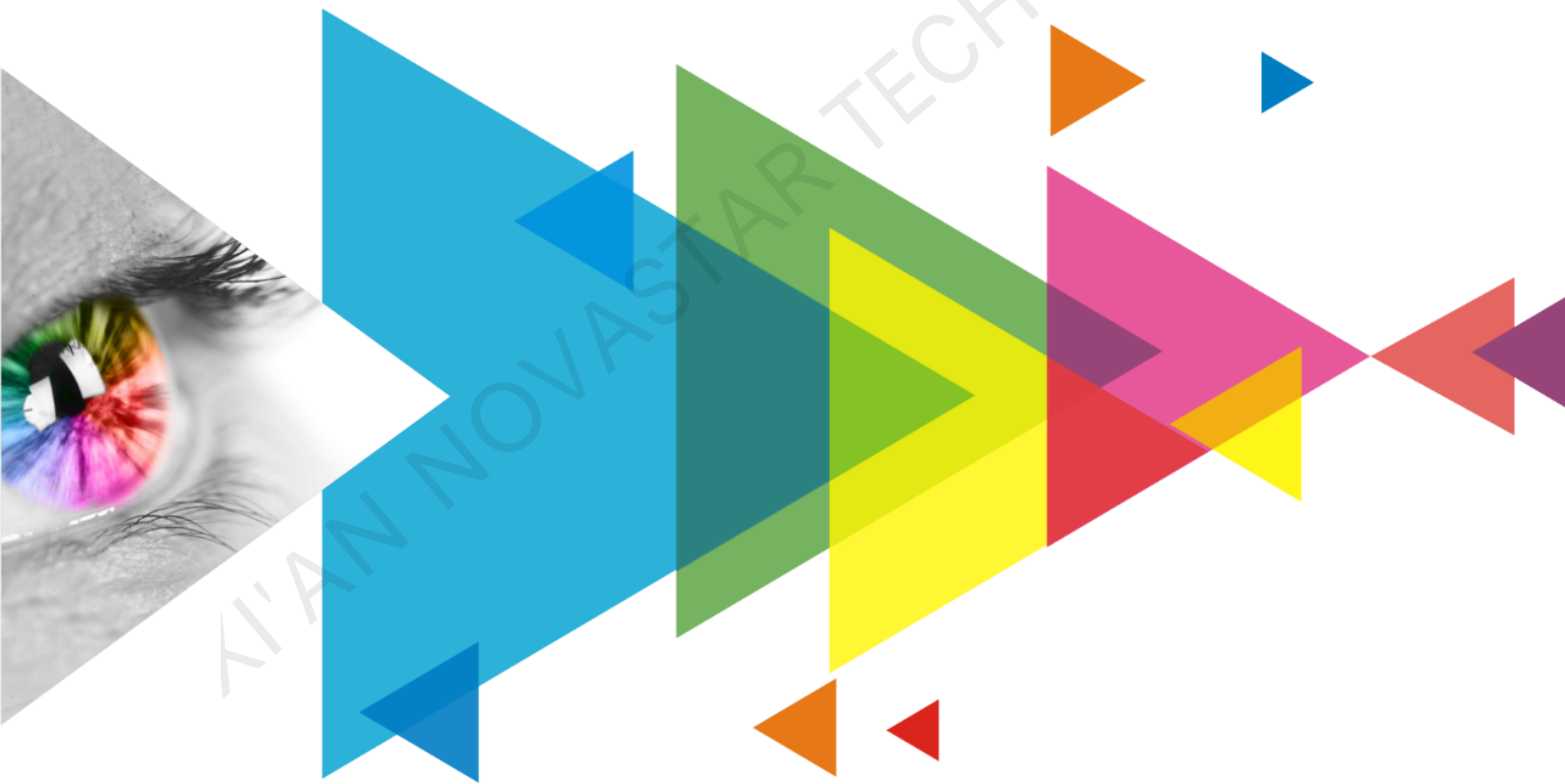

Specifications

Change History

Document Version	Release Date	Description
V2.1.7	2022-12-27	<ul style="list-style-type: none"> • Updated the dimensions diagram. • Updated the packing box dimensions. • Deleted the LVDS transmission.
V2.1.6	2022-08-31	Updated the input voltage.
V2.1.5	2022-03-26	<ul style="list-style-type: none"> • Added the dimensions diagram description. • Added the current and power consumption description. • Updated the certifications description. • Updated the feature description. • Updated the pins section.
V2.1.4	2021-08-25	<ul style="list-style-type: none"> • Updated the appearance diagram. • Updated the side-view dimensions diagram.
V2.1.3	2021-07-30	<ul style="list-style-type: none"> • Updated the description of features. • Added the certification related description.
V2.1.2	2021-02-06	<ul style="list-style-type: none"> • Added the dimensions diagram description. • Updated the loading capacity information. • Updated the packing information.
V2.1.1	2020-07-01	<ul style="list-style-type: none"> • Updated the firmware version. • Updated the indicator description. • Updated the side dimensions diagram. • Optimized the feature description. • Optimized the pin description tables.

Introduction

The A5s is a high-end small receiving card developed by Xi'an NovaStar Tech Co., Ltd. (hereinafter referred to as NovaStar). A single A5s supports resolutions up to 320x256@60Hz. Supporting the pixel level brightness and chroma calibration, individual gamma adjustment for RGB, and 3D functions, the A5s can significantly improve the display effect and user experience.

The A5s uses high-density connectors for communication to limit the effects of dust and vibration, resulting in high stability. It supports up to 32 groups of parallel RGB data or 64 groups of serial data (expandable to 128 groups of serial data). Its reserved pins allow for custom functions of users. Thanks to its EMC Class B compliant hardware design, the A5s has improved electromagnetic compatibility and is suitable for various on-site setups.

Certifications

RoHS, EMC Class B

If the product does not have the relevant certifications required by the countries or regions where it is to be sold, please contact NovaStar to confirm or address the problem. Otherwise, the customer shall be responsible for the legal risks caused or NovaStar has the right to claim compensation.

Features

Improvements to Display Effect

- Pixel level brightness and chroma calibration
Work with NovaStar's high-precision calibration system to calibrate the brightness and chroma of each pixel, effectively removing brightness differences and chroma differences, and enabling high brightness consistency and chroma consistency.
- Quick adjustment of dark or bright lines
The dark or bright lines caused by splicing of cabinets or modules can be adjusted to improve the visual experience. This function is easy to use and the adjustment takes effect immediately.
- 3D function
Working with the sending card that supports 3D function, the receiving card supports 3D image output.
- Individual gamma adjustment for RGB
Working with NovaLCT (V5.2.0 or later) and the sending card that supports this function, the receiving card supports individual adjustment of red gamma, green gamma and blue gamma, which can effectively control image non-uniformity at low grayscale conditions and white balance offset, allowing for a more realistic image.
- Image rotation in 90° increments
The display image can be set to rotate in multiples of 90° (0°/ 90°/180°/270°).

Improvements to Maintainability

- Smart module (dedicated firmware required)
Working with the smart module, the receiving card supports module ID management, storage of calibration coefficients and module parameters, monitoring of module temperature, voltage and flat cable communication status, LED error detection, and recording of the module run time.
- Automatic module calibration
After a new module with flash memory is installed to replace the old one, the calibration coefficients stored in the flash memory can be automatically uploaded to the receiving card when it is powered on.
- Quick uploading of calibration coefficients
The calibration coefficients can be quickly uploaded to the receiving card, improving efficiency greatly.
- Module Flash management
For modules with flash memory, the information stored in the memory can be managed. The calibration coefficients and module ID can be stored and read back.
- One click to apply calibration coefficients in module Flash
For modules with flash memory, when the Ethernet cable is disconnected, users can hold down the self-test button on the cabinet to upload the calibration coefficients in the flash memory of the module to the receiving card.
- Mapping function
The cabinets display the receiving card number and Ethernet port information, allowing users to easily obtain the locations and connection topology of receiving cards.
- Setting of a pre-stored image in receiving card
The image displayed during startup, or displayed when the Ethernet cable is disconnected or there is no video signal can be customized.
- Temperature and voltage monitoring
The temperature and voltage of the receiving card can be monitored without using peripherals.
- Cabinet LCD
The LCD module connected to the cabinet can display the temperature, voltage, single run time and total run time of the receiving card.
- Bit error detection
The Ethernet port communication quality of the receiving card can be monitored and the number of erroneous packets can be recorded to help troubleshoot network communication problems. NovaLCT V5.2.0 or later is required.
- Status detection of dual power supplies
When two power supplies are used, their working status can be detected by the receiving card.
- Firmware program readback
The firmware program of the receiving card can be read back and saved to the local computer. NovaLCT V5.2.0 or later is required.
- Configuration parameter readback
The configuration parameters of the receiving card can be read back and saved to the local computer.

Improvements to Reliability

- Dual card backup and status monitoring
In an application with requirements for high reliability, two receiving cards can be mounted onto a single hub board for backup. When the primary receiving card fails, the backup card can serve immediately to ensure uninterrupted operation of the display.

The working status of the primary and backup receiving cards can be monitored in NovaLCT V5.2.0 or later.

- Loop backup
The receiving cards and the sending card form a loop via the primary and backup line connections. When a fault occurs at a location of the lines, the screen can still display the image normally.
- Dual backup of configuration parameters
The receiving card configuration parameters are stored in the application area and factory area of

the receiving card at the same time. Users usually use the configuration parameters in the application area. If necessary, users can restore the configuration parameters in the factory area to the application area.

- Dual program backup
Two copies of firmware program are stored in the application area of the receiving card at the factory to avoid the problem that the receiving card may get stuck abnormally during program update.
- Dual backup of calibration coefficients
The calibration coefficients are stored in the application area and factory area of the receiving card at the same time. Users usually use the calibration coefficients in the application area. If necessary, users can restore the calibration coefficients in the factory area to the application area.

Appearance

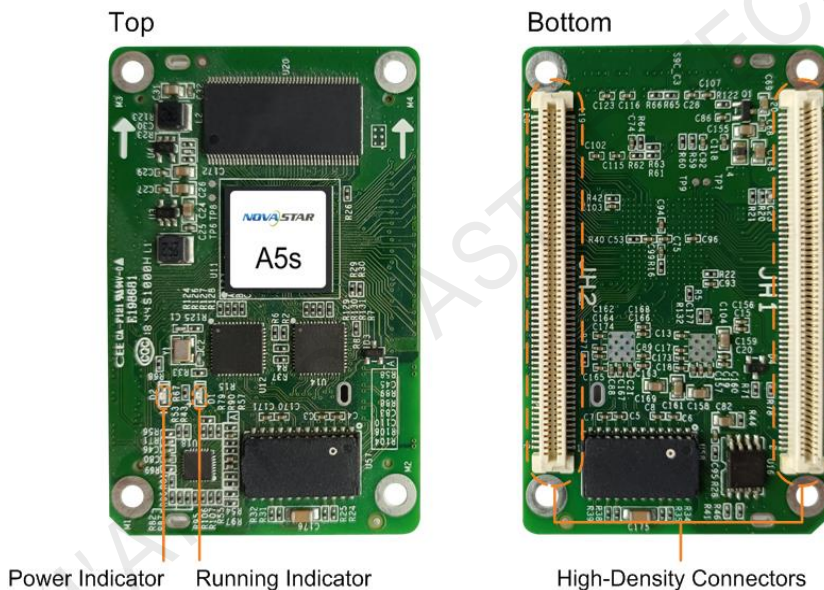

All product pictures shown in this document are for illustration purpose only. Actual product may vary.

Indicators

Indicator	Color	Status	Description
Running indicator	Green	Flashing once every 1s	The receiving card is functioning normally. Ethernet cable connection is normal, and video source input is available.
		Flashing once every 3s	Ethernet cable connection is abnormal.
		Flashing 3 times every 0.5s	Ethernet cable connection is normal, but no video source input is available.

Indicator	Color	Status	Description
		Flashing once every 0.2s	The receiving card failed to load the program in the application area and is now using the backup program.
		Flashing 8 times every 0.5s	A redundancy switchover occurred on the Ethernet port and the loop backup has taken effect.
Power indicator	Red	Always on	The power input is normal.

Dimensions

The board thickness is not greater than 2.0 mm, and the total thickness (board thickness + thickness of components on the top and bottom sides) is not greater than 8.7 mm. Ground connection (GND) is enabled for mounting holes.

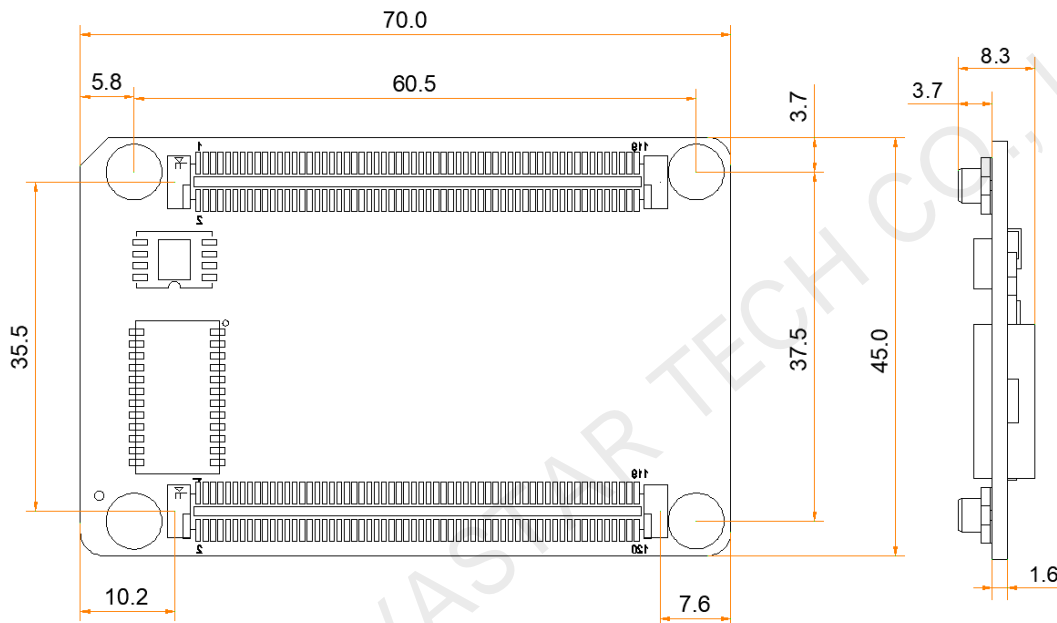

Tolerance: ± 0.3 Unit: mm

Note

The distance between outer surfaces of the A5s and hub boards after their high-density connectors fit together is 5.0 mm. A 5-mm copper pillar is recommended.

To make molds or trepan mounting holes, please contact NovaStar for a higher-precision structural drawing.

Pins

32 Groups of Parallel RGB Data

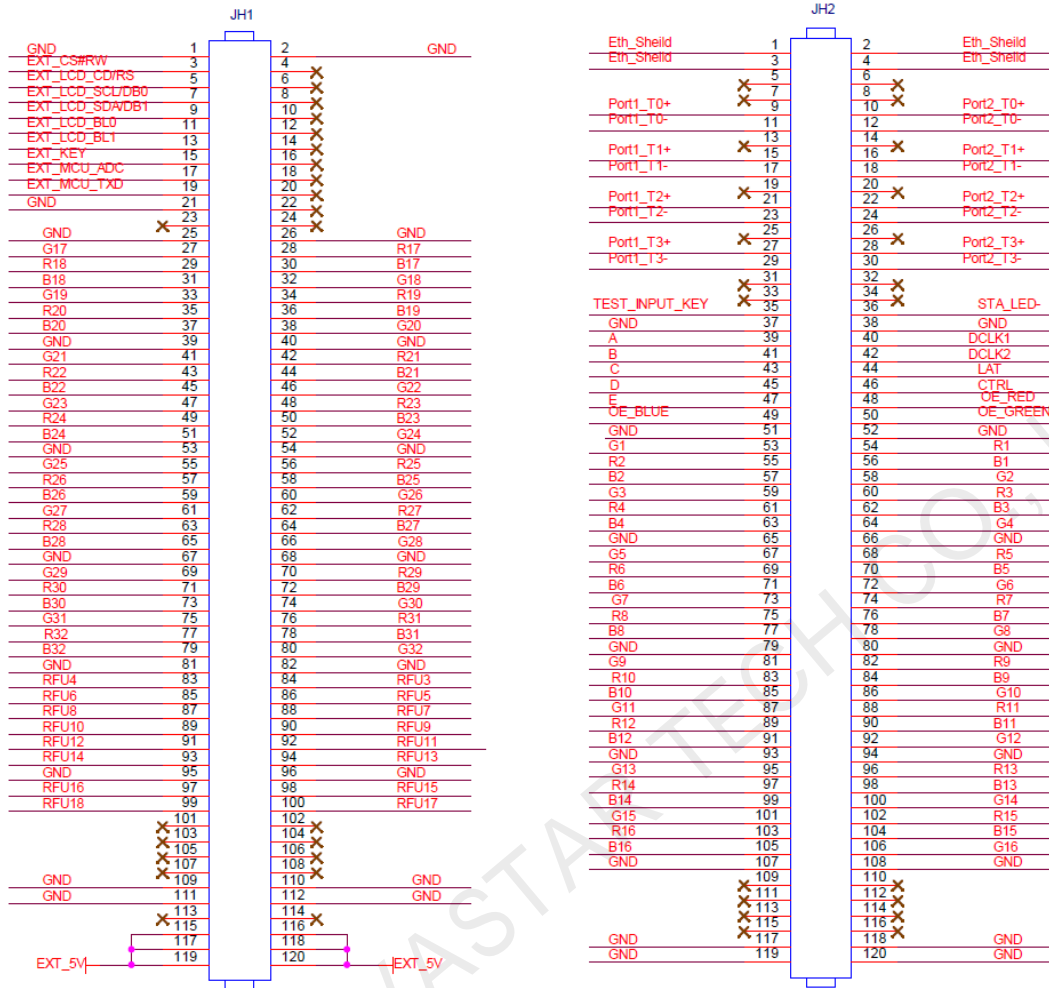

JH1					
	GND	1	2	GND	
LCD CS signal	EXT_CS#RW	3	4	NC	
LCD RS signal	EXT_LCD_CD/RS	5	6	NC	
LCD clock signal	EXT_LCD_SCL/DB0	7	8	NC	
LCD data signal	EXT_LCD_SDA/DB1	9	10	NC	
LCD backlight signal 1	EXT_LCD_BL0	11	12	NC	
LCD backlight signal 2	EXT_LCD_BL1	13	14	NC	
LCD control button	EXT_KEY	15	16	NC	
A reserved pin for MCU connection	EXT_MCU_ADC	17	18	NC	
A reserved pin for MCU connection	EXT_MCU_TXD	19	20	NC	
	GND	21	22	NC	
	NC	23	24	NC	
	GND	25	26	GND	
/	G17	27	28	R17	/
/	R18	29	30	B17	/
/	B18	31	32	G18	/
/	G19	33	34	R19	/
/	R20	35	36	B19	/
/	B20	37	38	G20	/
	GND	39	40	GND	
/	G21	41	42	R21	/
/	R22	43	44	B21	/
/	B22	45	46	G22	/
/	G23	47	48	R23	/

JH1					
/	R24	49	50	B23	/
/	B24	51	52	G24	/
	GND	53	54	GND	
/	G25	55	56	R25	/
/	R26	57	58	B25	/
/	B26	59	60	G26	/
/	G27	61	62	R27	/
/	R28	63	64	B27	/
/	B28	65	66	G28	/
	GND	67	68	GND	
/	G29	69	70	R29	/
/	R30	71	72	B29	/
/	B30	73	74	G30	/
/	G31	75	76	R31	/
/	R32	77	78	B31	/
/	B32	79	80	G32	/
	GND	81	82	GND	
/	RFU4	83	84	RFU3	/
/	RFU6	85	86	RFU5	/
/	RFU8	87	88	RFU7	/
/	RFU10	89	90	RFU9	/
/	RFU12	91	92	RFU11	/
/	RFU14	93	94	RFU13	/
	GND	95	96	GND	
/	RFU16	97	98	RFU15	/
/	RFU18	99	100	RFU17	/
	NC	101	102	NC	
	NC	103	104	NC	
	NC	105	106	NC	
	NC	107	108	NC	
	GND	109	110	GND	
	GND	111	112	GND	
	NC	113	114	NC	
	EXT_5V	115	116	EXT_5V	
	EXT_5V	117	118	EXT_5V	
	EXT_5V	119	120	EXT_5V	

JH2					
Chassis ground	Eth_Sheild	1	2	Eth_Sheild	Chassis ground
Chassis ground	Eth_Sheild	3	4	Eth_Sheild	Chassis ground
	NC	5	6	NC	
	NC	7	8	NC	
Gigabit Ethernet port	Port1_T0+	9	10	Port2_T0+	Gigabit Ethernet port
	Port1_T0-	11	12	Port2_T0-	
	NC	13	14	NC	
	Port1_T1+	15	16	Port2_T1+	
	Port1_T1-	17	18	Port2_T1-	
	NC	19	20	NC	
	Port1_T2+	21	22	Port2_T2+	
	Port1_T2-	23	24	Port2_T2-	
	NC	25	26	NC	
	Port1_T3+	27	28	Port2_T3+	
Port1_T3-	29	30	Port2_T3-		
	NC	31	32	NC	
	NC	33	34	NC	
Test button	TEST_INPUT_KEY	35	36	STA_LED-	Running indicator (active low)
	GND	37	38	GND	
Line decoding signal	A	39	40	DCLK1	Shift clock output 1
Line decoding signal	B	41	42	DCLK2	Shift clock output 2
Line decoding signal	C	43	44	LAT	Latch signal output
Line decoding signal	D	45	46	CTRL	Afterglow control signal
Line decoding signal	E	47	48	OE_RED	Display enable signal
Display enable signal	OE_BLUE	49	50	OE_GREEN	Display enable signal
	GND	51	52	GND	

JH2					
/	G1	53	54	R1	/
/	R2	55	56	B1	/
/	B2	57	58	G2	/
/	G3	59	60	R3	/
/	R4	61	62	B3	/
/	B4	63	64	G4	/
	GND	65	66	GND	
/	G5	67	68	R5	/
/	R6	69	70	B5	/
/	B6	71	72	G6	/
/	G7	73	74	R7	/
/	R8	75	76	B7	/
/	B8	77	78	G8	/
	GND	79	80	GND	
/	G9	81	82	R9	/
/	R10	83	84	B9	/
/	B10	85	86	G10	/
/	G11	87	88	R11	/
/	R12	89	90	B11	/
/	B12	91	92	G12	/
	GND	93	94	GND	
/	G13	95	96	R13	/
/	R14	97	98	B13	/
/	B14	99	100	G14	/
/	G15	101	102	R15	/
/	R16	103	104	B15	/
/	B16	105	106	G16	/
	GND	107	108	GND	
	NC	109	110	NC	
	NC	111	112	NC	
	NC	113	114	NC	
	NC	115	116	NC	
	GND	117	118	GND	
	GND	119	120	GND	

64 Groups of Serial Data

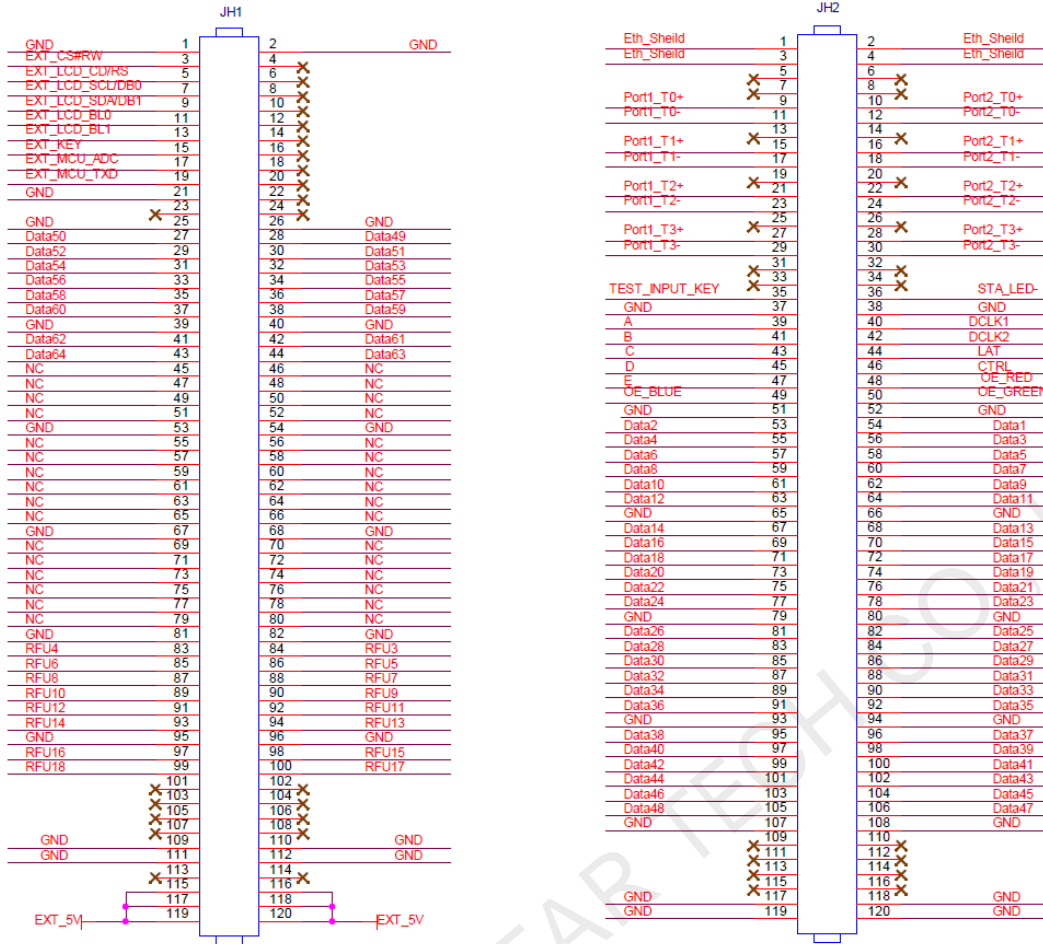

JH1					
	GND	1	2	GND	
LCD CS signal	EXT_CS#RW	3	4	NC	
LCD RS signal	EXT_LCD_CD/RS	5	6	NC	
LCD clock signal	EXT_LCD_SCL/DB0	7	8	NC	
LCD data signal	EXT_LCD_SDA/DB1	9	10	NC	
LCD backlight signal 1	EXT_LCD_BL0	11	12	NC	
LCD backlight signal 2	EXT_LCD_BL1	13	14	NC	
LCD control button	EXT_KEY	15	16	NC	
A reserved pin for MCU connection	EXT_MCU_ADC	17	18	NC	
A reserved pin for MCU connection	EXT_MCU_TXD	19	20	NC	
	GND	21	22	NC	
	NC	23	24	NC	
	GND	25	26	GND	
/	Data50	27	28	Data49	/
/	Data52	29	30	Data51	/
/	Data54	31	32	Data53	/
/	Data56	33	34	Data55	/
/	Data58	35	36	Data57	/
/	Data60	37	38	Data59	/
	GND	39	40	GND	
/	Data62	41	42	Data61	/
/	Data64	43	44	Data63	/
	NC	45	46	NC	
	NC	47	48	NC	
	NC	49	50	NC	
	NC	51	52	NC	
	GND	53	54	GND	
	NC	55	56	NC	

JH1					
	NC	57	58	NC	
	NC	59	60	NC	
	NC	61	62	NC	
	NC	63	64	NC	
	NC	65	66	NC	
	GND	67	68	GND	
	NC	69	70	NC	
	NC	71	72	NC	
	NC	73	74	NC	
	NC	75	76	NC	
	NC	77	78	NC	
	NC	79	80	NC	
	GND	81	82	GND	
/	RFU4	83	84	RFU3	/
/	RFU6	85	86	RFU5	/
/	RFU8	87	88	RFU7	/
/	RFU10	89	90	RFU9	/
/	RFU12	91	92	RFU11	/
/	RFU14	93	94	RFU13	/
	GND	95	96	GND	
/	RFU16	97	98	RFU15	/
/	RFU18	99	100	RFU17	/
	NC	101	102	NC	
	NC	103	104	NC	
	NC	105	106	NC	
	NC	107	108	NC	
	GND	109	110	GND	
	GND	111	112	GND	
	NC	113	114	NC	
	EXT_5V	115	116	EXT_5V	
	EXT_5V	117	118	EXT_5V	
	EXT_5V	119	120	EXT_5V	

JH2					
Chassis ground	Eth_Sheild	1	2	Eth_Sheild	Chassis ground
Chassis ground	Eth_Sheild	3	4	Eth_Sheild	Chassis ground
	NC	5	6	NC	
	NC	7	8	NC	
Gigabit Ethernet port	Port1_T0+	9	10	Port2_T0+	Gigabit Ethernet port
	Port1_T0-	11	12	Port2_T0-	
	NC	13	14	NC	
	Port1_T1+	15	16	Port2_T1+	
	Port1_T1-	17	18	Port2_T1-	
	NC	19	20	NC	
	Port1_T2+	21	22	Port2_T2+	
	Port1_T2-	23	24	Port2_T2-	
	NC	25	26	NC	
	Port1_T3+	27	28	Port2_T3+	
Port1_T3-	29	30	Port2_T3-		
	NC	31	32	NC	
	NC	33	34	NC	
Test button	TEST_INPUT_KEY	35	36	STA_LED-	Running indicator (active low)
	GND	37	38	GND	
Line decoding signal	A	39	40	DCLK1	Shift clock output 1
Line decoding signal	B	41	42	DCLK2	Shift clock output 2
Line decoding signal	C	43	44	LAT	Latch signal output
Line decoding signal	D	45	46	CTRL	Afterglow control signal
Line decoding signal	E	47	48	OE_RED	Display enable signal
Display enable signal	OE_BLUE	49	50	OE_GREEN	Display enable signal
	GND	51	52	GND	
/	Data2	53	54	Data1	/
/	Data4	55	56	Data3	/
/	Data6	57	58	Data5	/
/	Data8	59	60	Data7	/

JH2					
/	Data10	61	62	Data9	/
/	Data12	63	64	Data11	/
	GND	65	66	GND	
/	Data14	67	68	Data13	/
/	Data16	69	70	Data15	/
/	Data18	71	72	Data17	/
/	Data20	73	74	Data19	/
/	Data22	75	76	Data21	/
/	Data24	77	78	Data23	/
	GND	79	80	GND	
/	Data26	81	82	Data25	/
/	Data28	83	84	Data27	/
/	Data30	85	86	Data29	/
/	Data32	87	88	Data31	/
/	Data34	89	90	Data33	/
/	Data36	91	92	Data35	/
	GND	93	94	GND	
/	Data38	95	96	Data37	/
/	Data40	97	98	Data39	/
/	Data42	99	100	Data41	/
/	Data44	101	102	Data43	/
/	Data46	103	104	Data45	/
/	Data48	105	106	Data47	/
	GND	107	108	GND	
	NC	109	110	NC	
	NC	111	112	NC	
	NC	113	114	NC	
	NC	115	116	NC	
	GND	117	118	GND	
	GND	119	120	GND	

Note

The recommended power input is 5.0 V.

OE_RED, OE_GREEN and OE_BLUE are display enable signals. When RGB are not controlled separately, use OE_RED. When the PWM chip is used, they are used as GCLK signals.

In the mode of 128 groups of serial data, Data65–Data128 are multiplexed into Data1–Data64.

Reference Design for Extended Functions

Pins for Extended Functions			
Pin	Recommended Smart Module Pin	Recommended Module Flash Pin	Description
RFU3	HUB_CODE0	HUB_CODE0	Flash control pin 1
RFU4	HUB_SPI_CLK	HUB_SPI_CLK	Clock signal of serial pin
RFU5	HUB_CODE1	HUB_CODE1	Flash control pin 2
RFU6	HUB_SPI_CS	HUB_SPI_CS	CS signal of serial pin
RFU7	HUB_CODE2	HUB_CODE2	Flash control pin 3
RFU8	/	HUB_SPI_MOSI	Module Flash data storage input
	HUB_UART_TX	/	Smart module TX signal
RFU9	HUB_CODE3	HUB_CODE3	Flash control pin 4
RFU10	/	HUB_SPI_MISO	Module Flash data storage output
	HUB_UART_RX	/	Smart module RX signal
RFU11	HUB_H164_CSD	HUB_H164_CSD	74HC164 data signal
RFU12	/	/	/
RFU13	HUB_H164_CLK	HUB_H164_CLK	74HC164 clock signal
RFU14	POWER_STA1	POWER_STA1	Dual power supply detection signal 1
RFU15	MS_DATA	MS_DATA	Dual card backup connection signal
RFU16	POWER_STA2	POWER_STA2	Dual power supply detection signal 2
RFU17	MS_ID	MS_ID	Dual card backup identifier signal
RFU18	HUB_CODE4	HUB_CODE4	Flash control pin 5

 **Note**

The RFU8 and RFU10 are signal multiplex extension pins. Only one pin from either the Recommended Smart Module Pin or the Recommended Module Flash Pin can be selected at the same time.

Specifications

Maximum Resolution	320x256@60Hz	
Electrical Parameters	Input voltage	DC 3.8 V to 5.5 V
	Rated current	0.5 A
	Rated power consumption	2.5 W
Operating Environment	Temperature	-20°C to +70°C
	Humidity	10% RH to 90% RH, non-condensing
Storage Environment	Temperature	-25°C to +125°C
	Humidity	0% RH to 95% RH, non-condensing
Physical Specifications	Dimensions	70.0 mm × 45.0 mm × 8.3 mm
	Net weight	17.3 g Note: It is the weight of a single receiving card only.
Packing Information	Packing specifications	Each receiving card is packaged in a blister pack. Each packing box contains 80 receiving cards.
	Packing box dimensions	392.0 mm × 200.0 mm × 123.0 mm

The amount of current and power consumption may vary depending on various factors such as product settings, usage, and environment.

Copyright © 2022 Xi'an NovaStar Tech Co., Ltd. All Rights Reserved.

No part of this document may be copied, reproduced, extracted or transmitted in any form or by any means without the prior written consent of Xi'an NovaStar Tech Co., Ltd.

Trademark

NOVA STAR is a trademark of Xi'an NovaStar Tech Co., Ltd.

Statement

Thank you for choosing NovaStar's product. This document is intended to help you understand and use the product. For accuracy and reliability, NovaStar may make improvements and/or changes to this document at any time and without notice. If you experience any problems in use or have any suggestions, please contact us via the contact information given in this document. We will do our best to solve any issues, as well as evaluate and implement any suggestions.

Official website
www.novastar.tech

Technical support
support@novastar.tech