

AT20

Receiving Card

V1.3.1



Specifications

Change History

Document Version	Release Date	Description
V1.3.1	2020-09-18	<ul style="list-style-type: none"> Optimized the product introduction. Optimized the feature description. Optimized the legends in the appearance diagram. Optimized the indicator description. Optimized the dimensions diagram.
V1.3.0	2019-10-28	<ul style="list-style-type: none"> Changed the loading capacity from 320×256 pixels to 256×256 pixels. Added the function of image rotation in 90° increments. Added the function of dual backup of configuration parameters.
V1.2.0	2019-10-08	Upgraded the EMC certification to Class B standard.
V1.1.0	2019-07-30	<ul style="list-style-type: none"> Optimized the pin definition. Added the EMC Class A certification.
V1.0.0	2019-03-15	First release

Introduction

The AT20 is a general small receiving card developed by NovaStar. A single AT20 loads up to 256×256 pixels. Supporting various functions such as pixel level brightness and chroma calibration, quick adjustment of dark or bright lines, 3D, individual Gamma adjustment for RGB, and image rotation in 90° increments, the AT20 can greatly improve the display effect and user experience.

The AT20 uses high-density connectors for communication to limit the effects of dust and vibration, resulting in high stability. It supports up to 24 groups of parallel RGB data or 64 groups of serial data (expandable to 128 groups of serial data). Its reserved pins allow for custom functions of users. Thanks to its EMC Class B compliant hardware design, the AT20 has improved electromagnetic compatibility and is suitable to various on-site setups.

Features

Improvements to Display Effect

- Pixel level brightness and chroma calibration
Working with NovaLCT and NovaCLB, the receiving card supports brightness and chroma calibration on each LED, which can effectively remove color discrepancies and greatly improve LED display brightness and chroma consistency, allowing for better image quality.
- Quick adjustment of dark or bright lines
The dark or bright lines caused by splicing of modules and cabinets can be adjusted to improve the visual experience. The adjustment can be easily made and takes effect immediately.
- 3D function
Working with the sending card that supports 3D function, the receiving card supports 3D image output.
- Individual Gamma adjustment for RGB

Working with NovaLCT (V5.2.0 or later) and the sending card that supports this function, the receiving card supports individual adjustment of red Gamma, green Gamma and blue Gamma, which can effectively control image non-uniformity under low grayscale and white balance offset, allowing for a more realistic image.

- Image rotation in 90° increments
The display image can be set to rotate in multiples of 90° (0°/90°/180°/270°).

Improvements to Maintainability

- Smart module (dedicated firmware required)
Working with the smart module, the receiving card supports module ID management, storage of calibration coefficients and module parameters, monitoring of module temperature, voltage and flat cable communication status,

- LED error detection, and recording of the module run time.
- Automatic module calibration
After a new module with flash memory is installed to replace the old one, the calibration coefficients stored in the flash memory can be automatically uploaded to the receiving card when it is powered on.
- Module Flash management
For modules with flash memory, the information stored in the memory can be managed. The calibration coefficients and module ID can be stored and read back.
- One click to apply calibration coefficients stored in module Flash
For modules with flash memory, if the Ethernet cable is disconnected, users can hold down the self-test button on the cabinet to upload the calibration coefficients in the memory of the module to the receiving card.
- Mapping function
The cabinets can display the receiving card number and Ethernet port information, allowing users to easily obtain the locations and connection topology of receiving cards.
- Setting of a pre-stored image in receiving card
The image displayed on the screen during startup, or displayed when the Ethernet cable is disconnected or there is no video signal can be customized.
- Temperature and voltage monitoring
The receiving card temperature and voltage can be monitored without using peripherals.
- Cabinet LCD
The LCD module of the cabinet can display the temperature, voltage, single run time and total run time of the receiving card.
- Bit error rate monitoring
The Ethernet port communication quality of the receiving card can be monitored and the number of erroneous packets can be recorded to help troubleshoot network communication problems.
NovaLCT V5.2.0 or later is required.
- Firmware program readback
The receiving card firmware program can be read back and saved to the local computer.

NovaLCT V5.2.0 or later is required.

- Configuration parameter readback
The receiving card configuration parameters can be read back and saved to the local computer.
- LVDS transmission (dedicated firmware required)
Low-voltage differential signaling (LVDS) transmission is used to reduce the number of data cables from the hub board to module, increase the transmission distance, and improve the signal transmission quality and electromagnetic compatibility (EMC).

Improvements to Reliability

- Dual card backup and status monitoring
In an application with requirements for high reliability, two receiving cards can be mounted onto a single hub board for backup. If the main receiving card fails, the backup card can serve immediately to ensure uninterrupted operation of the display.
The working status of the main and backup receiving cards can be monitored in NovaLCT V5.2.0 or later.
- Status detection of dual power supplies
When two power supplies are connected, their working status can be detected by the receiving card.
- Loop backup
The receiving card and sending card form a loop via the main and backup line connections. If a fault occurs at a location of the lines, the screen can still display the image normally.
- Dual backup of configuration parameters
The receiving card configuration parameters are stored in the application area and factory area of the receiving card at the same time. Users usually use the configuration parameters in the application area. If necessary, users can restore the configuration parameters in the factory area to the application area.
- Dual backup of the application program
Two copies of the application program are stored in the receiving card at the factory to avoid the problem that the receiving card may get stuck due to program update exception.

Appearance

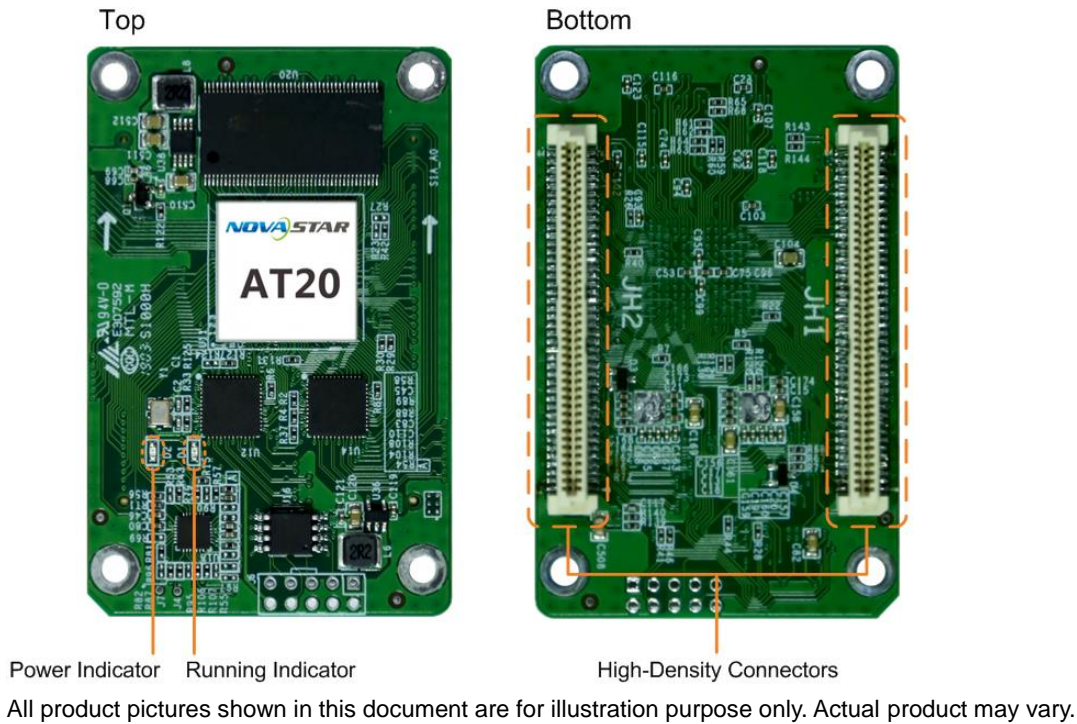

Indicators

Indicator	Color	Status	Description
Running indicator	Green	Flashing once every 1s	The receiving card is functioning normally. Ethernet cable connection is normal, and video source input is available.
		Flashing once every 3s	Ethernet cable connection is abnormal.
		Flashing 3 times every 0.5s	Ethernet cable connection is normal, but no video source input is available.
		Flashing once every 0.2s	The receiving card failed to load the program in the application area and now is using the backup program.
		Flashing 8 times every 0.5s	A redundancy switchover occurred on the Ethernet port and the loop backup has taken effect.
Power indicator	Red	Always on	The power supply is normal.

Dimensions

The board thickness is not greater than 2.0 mm, and the total thickness (board thickness + thickness of components on the top and bottom sides) is not greater than 9.5 mm. Ground connection (GND) is enabled for mounting holes.

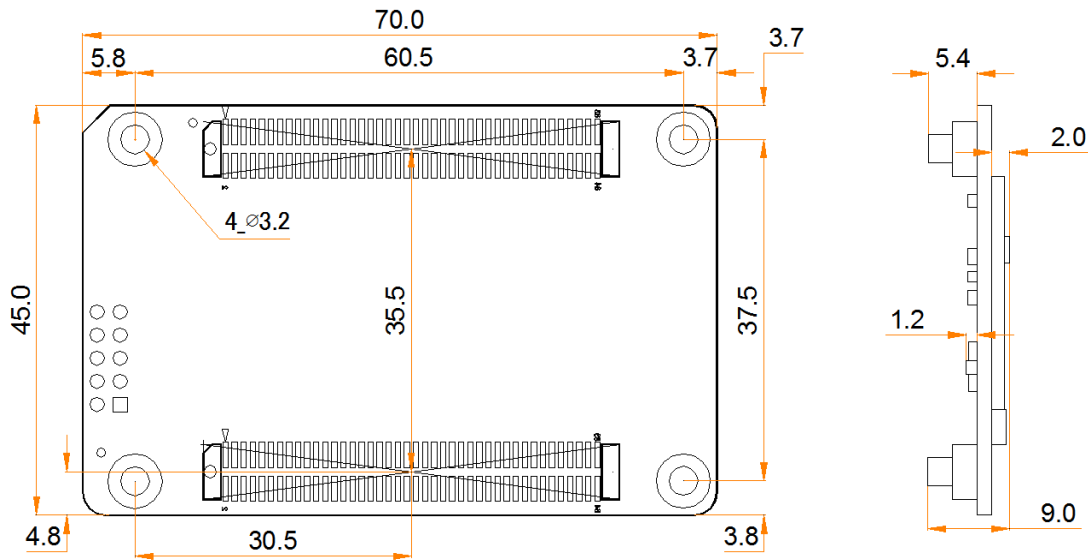

Tolerance: ±0.1 Unit: mm

Note

The distance between outer surfaces of the AT20 and HUB boards after their high-density connectors fit together is 8.0 mm. An 8-mm copper pillar is recommended.

Pins

24 Groups of Parallel RGB Data

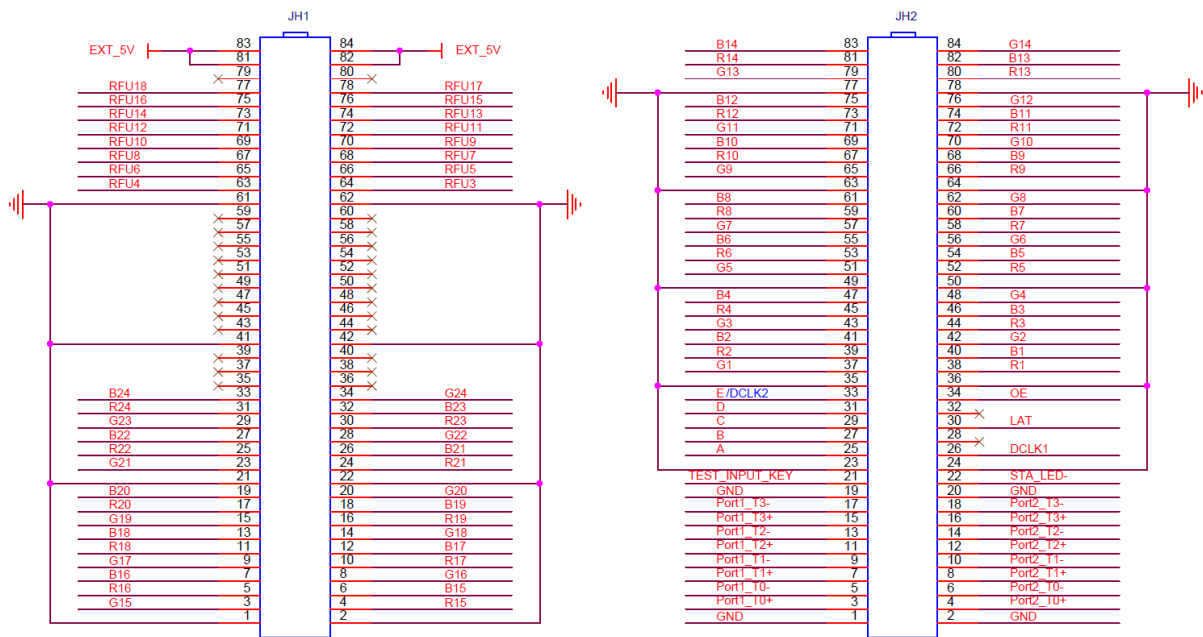

JH1						JH2					
5V	EXT_5V	83	84	EXT_5V	5V	/	B14	83	84	G14	/
	EXT_5V	81	82	EXT_5V		/	R14	81	82	B13	/
/	NC	79	80	NC	/	/	G13	79	80	R13	/
Reserved	RFU18	77	78	RFU17	Reserved	Ground	GND	77	78	GND	Ground
	RFU16	75	76	RFU15		/	B12	75	76	G12	/
	RFU14	73	74	RFU13		/	R12	73	74	B11	/
	RFU12	71	72	RFU11		/	G11	71	72	R11	/

JH1						JH2					
	RFU10	69	70	RFU9		/	B10	69	70	G10	/
	RFU8	67	68	RFU7		/	R10	67	68	B9	/
	RFU6	65	66	RFU5		/	G9	65	66	R9	/
	RFU4	63	64	RFU3		Ground	GND	63	64	GND	Ground
Ground	GND	61	62	GND	Ground	/	B8	61	62	G8	/
/	NC	59	60	NC	/	/	R8	59	60	B7	/
/	NC	57	58	NC	/	/	G7	57	58	R7	/
/	NC	55	56	NC	/	/	B6	55	56	G6	/
/	NC	53	54	NC	/	/	R6	53	54	B5	/
/	NC	51	52	NC	/	/	G5	51	52	R5	/
/	NC	49	50	NC	/	Ground	GND	49	50	GND	Ground
/	NC	47	48	NC	/	/	B4	47	48	G4	/
/	NC	45	46	NC	/	/	R4	45	46	B3	/
/	NC	43	44	NC	/	/	G3	43	44	R3	/
Ground	GND	41	42	GND	Ground	/	B2	41	42	G2	/
/	NC	39	40	NC	/	/	R2	39	40	B1	/
/	NC	37	38	NC	/	/	G1	37	38	R1	/
/	NC	35	36	NC	/	Ground	GND	35	36	GND	Ground
/	B24	33	34	G24	/	Line decoding signal	E/DCLK2	33	34	OE	Display enable
/	R24	31	32	B23	/		D	31	32	NC	/
/	G23	29	30	R23	/		C	29	30	LAT	Latch signal output
/	B22	27	28	G22	/		B	27	28	NC	/
/	R22	25	26	B21	/		A	25	26	DCLK1	Shift clock output
/	G21	23	24	R21	/	Ground	GND	23	24	GND	Ground
Ground	GND	21	22	GND	Ground	Test button	TEST_IN PUT_KEY	21	22	STA_LED-	Running indicator
/	B20	19	20	G20	/	Ground	GND	19	20	GND	Ground
/	R20	17	18	B19	/	Gigabit Ethernet port	Port1_T3-	17	18	Port2_T3-	Gigabit Ethernet port
/	G19	15	16	R19	/		Port1_T3+	15	16	Port2_T3+	
/	B18	13	14	G18	/		Port1_T2-	13	14	Port2_T2-	
/	R18	11	12	B17	/		Port1_T2+	11	12	Port2_T2+	
/	G17	9	10	R17	/		Port1_T1-	9	10	Port2_T1-	
/	B16	7	8	G16	/		Port1_T1+	7	8	Port2_T1+	
/	R16	5	6	B15	/		Port1_T0-	5	6	Port2_T0-	
/	G15	3	4	R15	/		Port1_T0+	3	4	Port2_T0+	
Ground	GND	1	2	GND	Ground	Ground	GND	1	2	GND	Ground

64 Groups of Serial Data

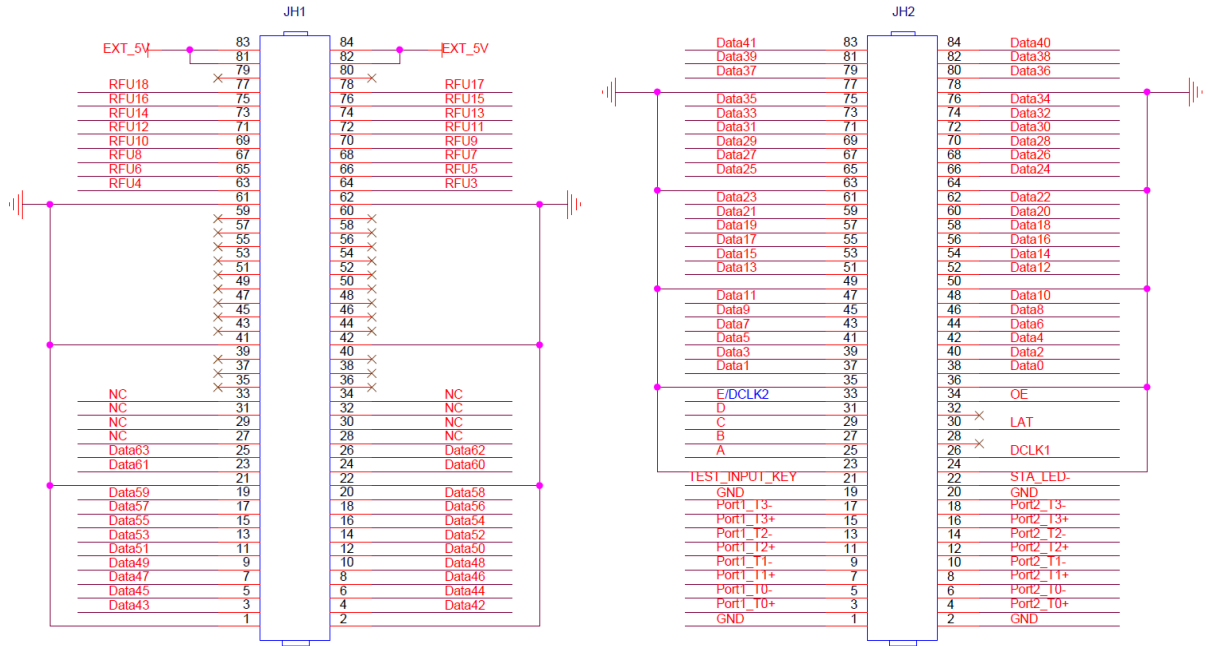

JH1						JH2					
5V	EXT_5V	83	84	EXT_5V	5V	/	Data41	83	84	Data	/
	EXT_5V	81	82	EXT_5V		/	Data39	81	82	Data	/
/	NC	79	80	NC	/	/	Data37	79	80	Data	/
Reserved	RFU18	77	78	RFU17	Reserved	Ground	GND	77	78	GND	Ground
	RFU16	75	76	RFU15		/	Data35	75	76	Data34	/
	RFU14	73	74	RFU13		/	Data33	73	74	Data32	/
	RFU12	71	72	RFU11		/	Data31	71	72	Data30	/
	RFU10	69	70	RFU9		/	Data29	69	70	Data28	/
	RFU8	67	68	RFU7		/	Data27	67	68	Data26	/
	RFU6	65	66	RFU5		/	Data25	65	66	Data24	/
Ground	GND	61	62	GND	Ground	Ground	GND	63	64	GND	Ground
/	NC	59	60	NC	/	/	Data23	61	62	Data22	/
/	NC	57	58	NC	/	/	Data21	59	60	Data20	/
/	NC	55	56	NC	/	/	Data19	57	58	Data18	/
/	NC	53	54	NC	/	/	Data17	55	56	Data16	/
/	NC	51	52	NC	/	/	Data15	53	54	Data14	/
/	NC	49	50	NC	/	Ground	GND	49	50	GND	Ground
/	NC	47	48	NC	/	/	Data11	47	48	Data10	/
/	NC	45	46	NC	/	/	Data9	45	46	Data8	/
/	NC	43	44	NC	/	/	Data7	43	44	Data6	/
Ground	GND	41	42	GND	Ground	/	Data5	41	42	Data4	/
/	NC	39	40	NC	/	/	Data3	39	40	Data2	/
/	NC	37	38	NC	/	/	Data1	37	38	Data0	/
/	NC	35	36	NC	/	Ground	GND	35	36	GND	Ground
/	NC	33	34	NC	/	Line decoding signal	E/DCLK2	33	34	OE	Display enable
/	NC	31	32	NC	/		D	31	32	NC	/
/	NC	29	30	NC	/		C	29	30	LAT	Latch signal output

JH1						JH2					
/	NC	27	28	NC	/		B	27	28	NC	/
/	Data63	25	26	Data62	/		A	25	26	DCLK1	Shift clock output
/	Data61	23	24	Data60	/	Ground	GND	23	24	GND	Ground
Ground	GND	21	22	GND	Ground	Test button	TEST_IN PUT_KEY	21	22	STA_LED-	Running indicator
/	Data59	19	20	Data58	/	Ground	GND	19	20	GND	Ground
/	Data57	17	18	Data56	/	Gigabit Ethernet port	Port1_T3-	17	18	Port2_T3-	Gigabit Ethernet port
/	Data55	15	16	Data54	/		Port1_T3+	15	16	Port2_T3+	
/	Data53	13	14	Data52	/		Port1_T2-	13	14	Port2_T2-	
/	Data51	11	12	Data50	/		Port1_T2+	11	12	Port2_T2+	
/	Data49	9	10	Data48	/		Port1_T1-	9	10	Port2_T1-	
/	Data47	7	8	Data46	/		Port1_T1+	7	8	Port2_T1+	
/	Data45	5	6	Data44	/		Port1_T0-	5	6	Port2_T0-	
/	Data43	3	4	Data42	/		Port1_T0+	3	4	Port2_T0+	
Ground	GND	1	2	GND	Ground		Ground	GND	1	2	

Reference Design for Extended Functions

Description of Pins for Extended Functions			
Pin	Recommended Module Flash Pin	Recommended Smart Module Pin	Description
RFU4	HUB_SPI_CLK	(Reserved)	Clock signal of serial pin
RFU6	HUB_SPI_CS	(Reserved)	CS signal of serial pin
RFU8	HUB_SPI_MOSI	/	Module Flash data storage input
	/	HUB_UART_TX	Smart module TX signal
RFU10	HUB_SPI_MISO	/	Module Flash data storage output
	/	HUB_UART_RX	Smart module RX signal
RFU3	HUB_CODE0		Module Flash BUS control pin
RFU5	HUB_CODE1		
RFU7	HUB_CODE2		
RFU9	HUB_CODE3		
RFU14	POWER_STA1		
RFU16	POWER_STA2		
RFU15	MS_DATA		Dual card backup connection signal
RFU17	MS_ID		Dual card backup identifier signal
RFU11	NC		/
RFU12	NC		/
RFU13	NC		/
RFU18	NC		/

Note

The RFU8 and RFU10 are signal multiplex extension pins. Only one pin from either the Recommended Smart Module Pin or the Recommended Module Flash Pin can be selected at the same time.

Specifications

Maximum Loading Capacity	256 × 256 pixels	
Electrical Specifications	Input voltage	DC 3.3 V to 5.5 V
	Rated current	0.5 A
	Rated power consumption	2.5 W

Operating Environment	Temperature	-20°C to +70°C
	Humidity	10% RH to 90% RH, non-condensing
Storage Environment	Temperature	-25°C to +125°C
	Humidity	0% RH to 95% RH, non-condensing
Physical Specifications	Dimensions	70.0 mm × 45.0 mm × 9.0 mm
	Net weight	17.2 g
Packing Information	Packing specifications	An antistatic bag and anti-collision foam are provided for each receiving card. Each packing box contains 40 receiving cards.
	Packing box dimensions	378.0 mm × 190.0 mm × 120.0 mm
Certifications	RoHS, EMC Class B	

The amount of current and power consumption may vary depending on factors such as product settings, usage, and environment.

Copyright © 2020 Xi'an NovaStar Tech Co., Ltd. All Rights Reserved.

No part of this document may be copied, reproduced, extracted or transmitted in any form or by any means without the prior written consent of Xi'an NovaStar Tech Co., Ltd.

Trademark

 is a trademark of Xi'an NovaStar Tech Co., Ltd.

Statement

Thank you for choosing NovaStar's product. This document is intended to help you understand and use the product. For accuracy and reliability, NovaStar may make improvements and/or changes to this document at any time and without notice. If you experience any problems in use or have any suggestions, please contact us via the contact information given in this document. We will do our best to solve any issues, as well as evaluate and implement any suggestions.

| [Official website](http://www.novastar.tech)
| www.novastar.tech

| [Technical support](mailto:support@novastar.tech)
| support@novastar.tech