

MRV266

Receiving Card

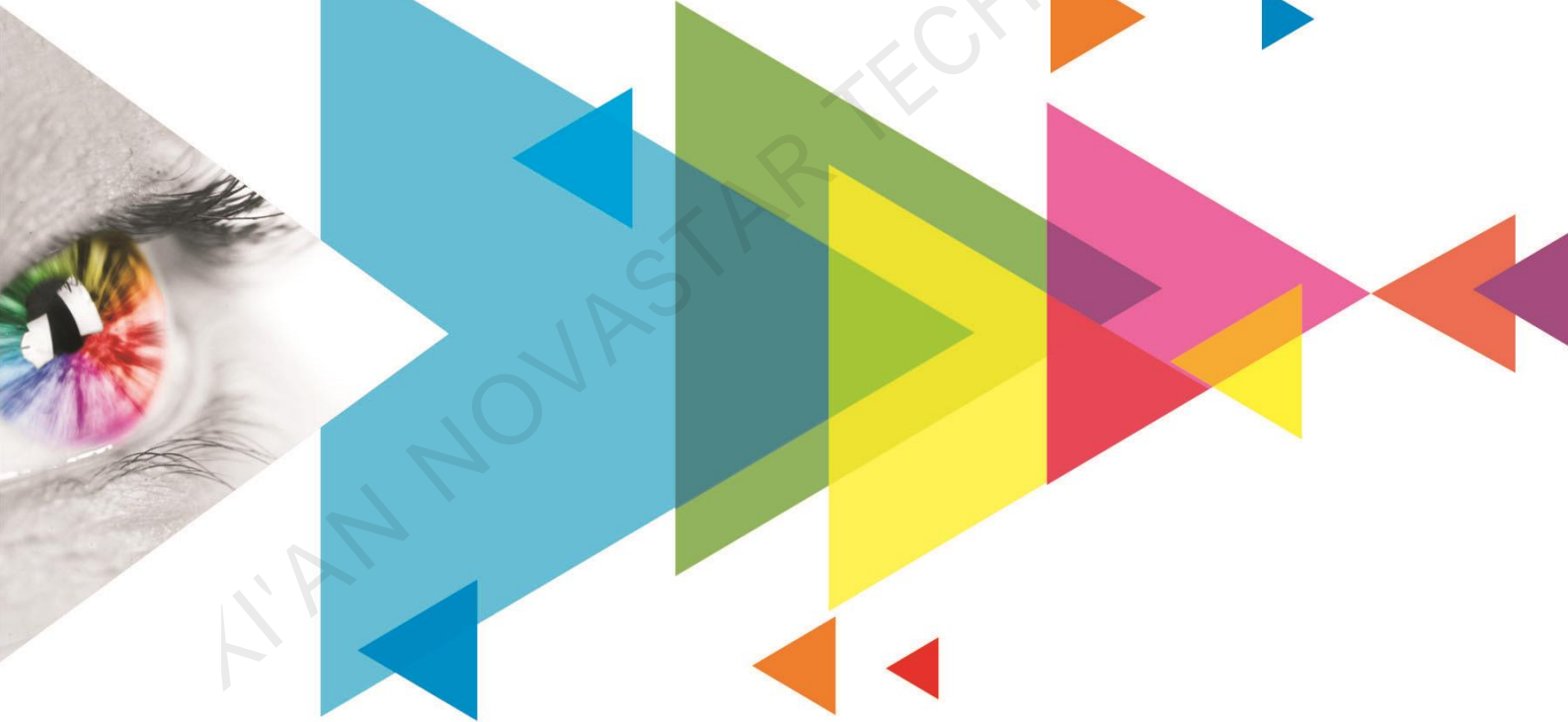

Specifications

Change History

| Document Version | Release Date | Description |
|------------------|--------------|--|
| V1.1.3 | 2022-12-27 | <ul style="list-style-type: none"> Updated the description of the maximum resolution. Updated the dimensions diagram. |
| V1.1.2 | 2022-08-31 | <ul style="list-style-type: none"> Added the table of appearance description. Updated the appearance diagram. Updated the input voltage. Updated the packing information. |
| V1.1.1 | 2022-03-26 | <ul style="list-style-type: none"> Added the certifications description. Added the dimensions diagram description. Updated some feature descriptions. |
| V1.1.0 | 2020-09-11 | <ul style="list-style-type: none"> Updated the maximum loading capacity. Optimized the feature description. Optimized the legends in the appearance diagram. Optimized the indicator description. Optimized the dimensions diagram style. |
| V1.0.1 | 2019-10-30 | Increased the version number only. |
| V1.0.0 | 2019-03-15 | First release |

Introduction

The MRV266 is a receiving card developed by Xi'an NovaStar Tech Co., Ltd. (hereinafter referred to as NovaStar) for fine-pitch LED screens. For PWM driver ICs, a single MRV266 supports resolutions up to 512x384@60Hz. Supporting various functions such as the brightness calibration, quick adjustment of dark or bright lines, 3D, and individual gamma adjustment for RGB, the MRV266 can significantly improve the display effect and user experience.

The MRV266 uses 6 HUB320 (26 pins) connectors for communication, resulting in high stability. It supports up to 24 groups of parallel RGB data and is suitable for various on-site setups.

Certifications

RoHS

If the product does not have the relevant certifications required by the countries or regions where it is to be sold, please contact NovaStar to confirm or address the problem. Otherwise, the customer shall be responsible for the legal risks caused or NovaStar has the right to claim compensation.

Features

Improvements to Display Effect

- Brightness calibration**
 Work with NovaStar's high-precision calibration system to calibrate the brightness of each pixel, effectively removing brightness differences and enabling high brightness consistency.
- Quick adjustment of dark or bright lines**
 The dark or bright lines caused by splicing of modules and cabinets can be adjusted to improve the visual experience. The adjustment can be easily made and takes effect immediately.

- **3D function**
Working with the sending card that supports 3D function, the receiving card supports 3D image output.
- **Individual gamma adjustment for RGB**
Working with NovaLCT (V5.2.0 or later) and the sending card that supports this function, the receiving card supports individual adjustment of red gamma, green gamma and blue gamma, which can effectively control image non-uniformity under low grayscale and white balance offset, allowing for a more realistic image.

Improvements to Maintainability

- **Mapping function**
The cabinets display the receiving card number and Ethernet port information, allowing users to easily obtain the locations and connection topology of receiving cards.
- **Temperature and voltage monitoring**
The temperature and voltage of the receiving card can be monitored without using peripherals.
- **Cabinet LCD**
The LCD module connected to the cabinet can display the temperature, voltage, single run time and total run time of the receiving card.
- **Bit error detection**
The Ethernet port communication quality of the receiving card can be monitored and the number of erroneous packets can be recorded to help troubleshoot network communication problems. NovaLCT V5.2.0 or later is required.
- **Firmware program readback**
The receiving card firmware program can be read back and saved to the local computer. NovaLCT V5.2.0 or later is required.
- **Configuration parameter readback**
The receiving card configuration parameters can be read back and saved to the local computer.

Improvements to Reliability

- **Loop backup**
The receiving card and sending card form a loop via the main and backup line connections. If a fault occurs at a location of the lines, the screen can still display the image normally.
- **Dual backup of configuration parameters**
The receiving card configuration parameters are stored in the application area and factory area of the receiving card at the same time. Users usually use the configuration parameters in the application area. If necessary, users can restore the configuration parameters in the factory area to the application area.
- **Dual program backup**
Two copies of firmware program are stored in the application area of the receiving card at the factory to avoid the problem that the receiving card may get stuck abnormally during program update.

Appearance

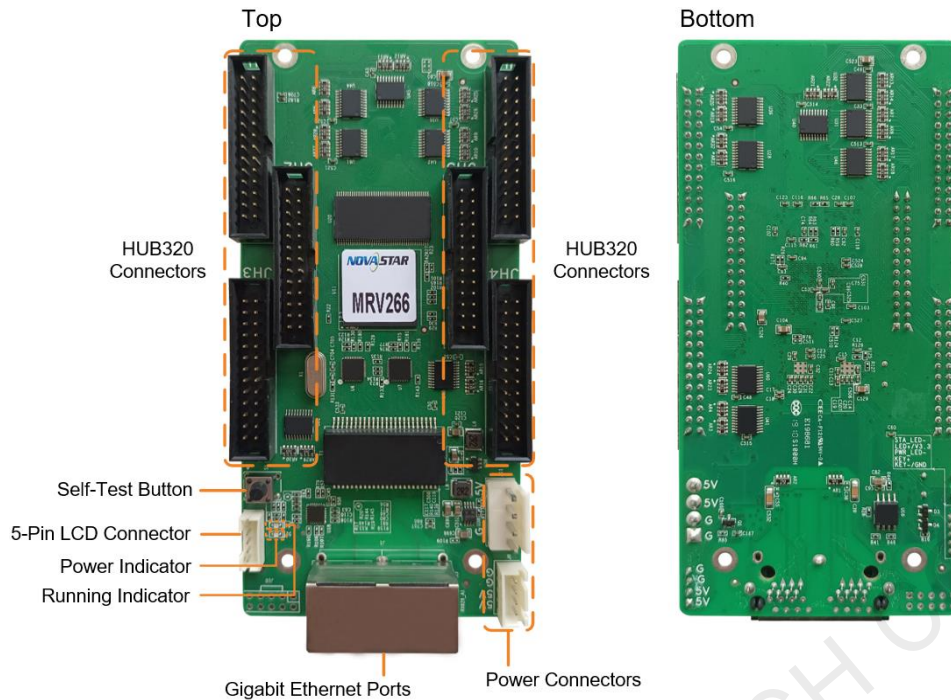

All product pictures shown in this document are for illustration purpose only. Actual product may vary.

| Name | Description |
|------------------------|--|
| HUB320 Connectors | Connect to the module. |
| Power Connectors | Connect to the input power. Either of the connectors can be chosen. |
| Gigabit Ethernet Ports | Connect to the sending card, and cascade other receiving cards. Each connector can be used as input or output. |
| Self-Test Button | Set the test pattern. After the Ethernet cable is disconnected, press the button twice, and the test pattern will be displayed on the screen. Press the button again to switch the pattern. |
| 5-Pin LCD Connector | Connect to the LCD. |

Indicators

| Indicator | Color | Status | Description |
|-------------------|-------|---------------------------|---|
| Running indicator | Green | Flashing once every 1s | The receiving card is functioning normally. Ethernet cable connection is normal, and video source input is available. |
| | | Flashing once every 3s | Ethernet cable connection is abnormal. |
| | | Flashing 3 times every 1s | Ethernet cable connection is normal, but no video source input is available. |
| | | Flashing once every 0.5s | The receiving card failed to load the program in the application area and is now using the backup program. |
| | | Flashing 8 times every 1s | A redundancy switchover occurred on the Ethernet port and the loop backup has taken effect. |

| Indicator | Color | Status | Description |
|-----------------|-------|-----------|-----------------------------|
| Power indicator | Red | Always on | The power supply is normal. |

Dimensions

The board thickness is not greater than 2.0 mm, and the total thickness (board thickness + thickness of components on the top and bottom sides) is not greater than 17.5 mm. Ground connection (GND) is enabled for mounting holes.

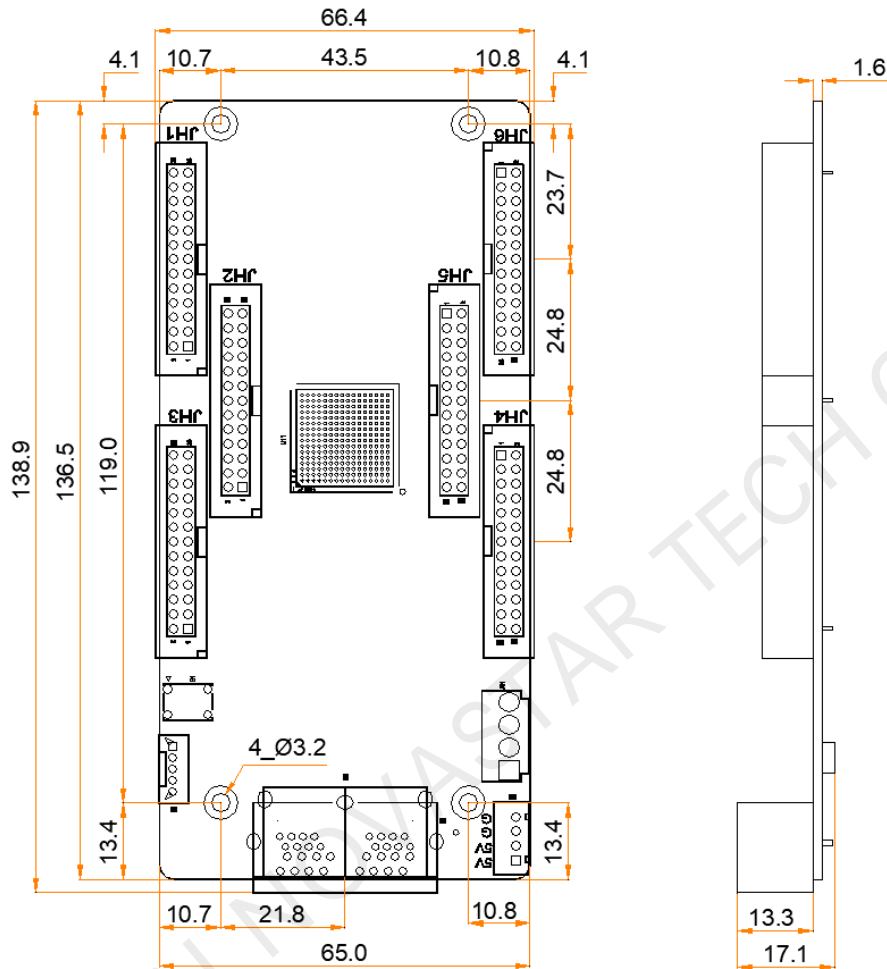

Tolerance: ± 0.3 Unit: mm

To make molds or trepan mounting holes, please contact NovaStar for a higher-precision structural drawing.

Pins

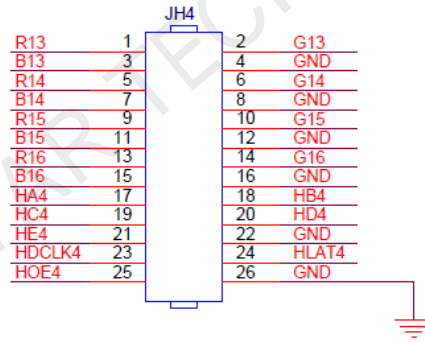
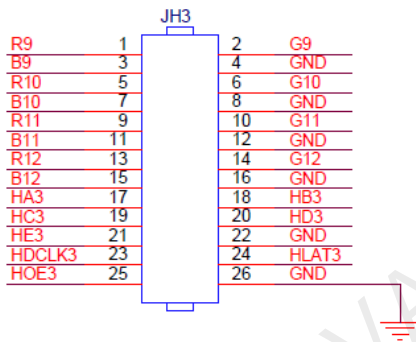
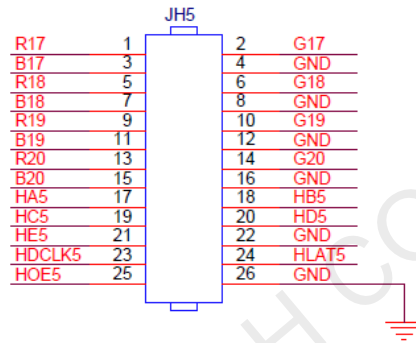
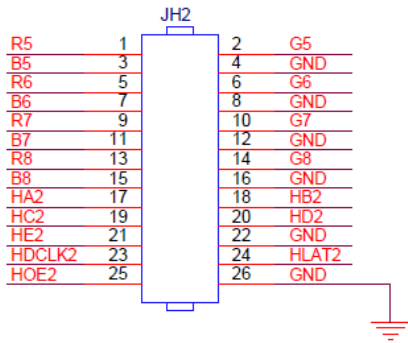
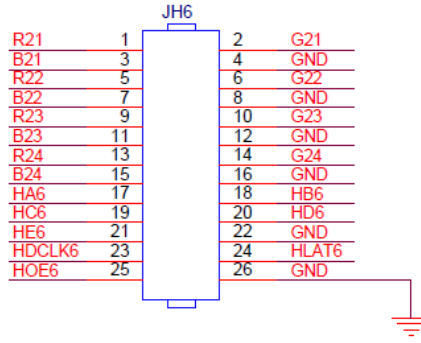
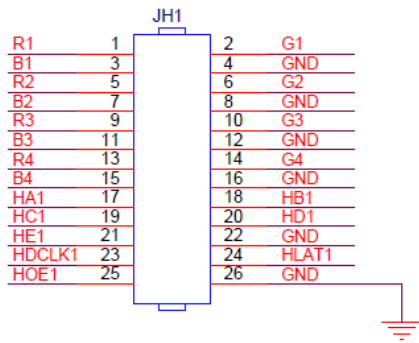

| Pin Definitions | | | | | | |
|-----------------------|------|----|----|-----|----------------------|--|
| / | R | 1 | 2 | G | / | |
| / | B | 3 | 4 | GND | Ground | |
| / | R | 5 | 6 | G | / | |
| / | B | 7 | 8 | GND | Ground | |
| / | R | 9 | 10 | G | / | |
| / | B | 11 | 12 | GND | Ground | |
| / | R | 13 | 14 | G | / | |
| / | B | 15 | 16 | GND | Ground | |
| Line decoding signal | HA | 17 | 18 | HB | Line decoding signal | |
| Line decoding signal | HC | 19 | 20 | HD | Line decoding signal | |
| Line decoding signal | HE | 21 | 22 | GND | Ground | |
| Shift clock | DCLK | 23 | 24 | LAT | Latch signal | |
| Display enable signal | OE | 25 | 26 | GND | Ground | |

Specifications

| | | |
|---------------------------|-------------------------------|--|
| Maximum Resolution | 512×384@60Hz (PWM driver ICs) | |
| Electrical Specifications | Input voltage | DC 3.8 V to 5.5 V |
| | Rated current | 0.5 A |
| | Rated power consumption | 2.5 W |
| Operating Environment | Temperature | -20°C to +70°C |
| | Humidity | 10% RH to 90% RH, non-condensing |
| Storage Environment | Temperature | -25°C to +125°C |
| | Humidity | 0% RH to 95% RH, non-condensing |
| Physical Specifications | Dimensions | 138.9 mm × 66.4 mm × 17.1 mm |
| | Net weight | 68.0 g Note: It is the weight of a single receiving card only. |
| Packing Information | Packing specifications | An antistatic bag and anti-collision foam are provided for each receiving card. Each packing box contains 100 receiving cards. |
| | Packing box dimensions | 625.0 mm × 180.0 mm × 470.0 mm |

The amount of current and power consumption may vary depending on various factors such as product settings, usage, and environment.

Copyright © 2022 Xi'an NovaStar Tech Co., Ltd. All Rights Reserved.

No part of this document may be copied, reproduced, extracted or transmitted in any form or by any means without the prior written consent of Xi'an NovaStar Tech Co., Ltd.

Trademark

NOVA STAR is a trademark of Xi'an NovaStar Tech Co., Ltd.

Statement

Thank you for choosing NovaStar's product. This document is intended to help you understand and use the product. For accuracy and reliability, NovaStar may make improvements and/or changes to this document at any time and without notice. If you experience any problems in use or have any suggestions, please contact us via the contact information given in this document. We will do our best to solve any issues, as well as evaluate and implement any suggestions.

Official website
www.novastar.tech

Technical support
support@novastar.tech